



SERIE 124 ■

COUPLINGS, MULTICOUPLINGS & MOULD COOLING PRODUCTS

KUPPLUNGEN, MULTIKUPPLUNGEN & KÜHLUNGSELEMENTE FÜR WERKZEUGE



Interchangeability - Kompatibilität
STAUBLI SPX

Temperature Range - Temperaturbereich
-10°C +150°C (+14°F +302°F)

Working Pressure - Betriebsdruck
06 serie 450 bar (6525 PSI)
08 serie 450 bar (6525 PSI)
12 serie 350 bar (5075 PSI)
16 serie 350 bar (5075 PSI)

Flow capacity - Nennweite
124.06 - Ø 6
124.08 - Ø 8
124.12 - Ø 12
124.16 - Ø 16

Options - Optionen

PD - Connected under residual pressure.
(only unavailable for 124.06 socket)
Einkuppeln unter Restdruck (verfügbar nur für 124.06)

PK - Dust protection cover to protect entering contamination..) -
Gekoppelte Ausführung verhindert das Eindringen von Verschmutzungen

KE - Safety locking system to prevent accidental disconnection. -
Sicherheitsverriegelung für unbeabsichtigtes Betätigen der Schiebühse.

KS - Integrated sealing kit. - Integrierte Dichtung.

Material - Material

Coupler body - Kupplungsgrundkörper	:AISI - 420 chrome steel :AISI - 420 Chromstahl
Back Part - Hinterteil	:Steel & galvanized - Stahl Verzinkt
Sleeve - Hülse	:AISI - 420 chrome steel - :AISI - 420 Chromstahl
Valve - Ventil	:AISI - 420 chrome steel :AISI - 420 Chromstahl
Springs - Federn	:AISI - 302
Balls -Kugeln	:AISI - 420
Seals - Dichtungen	:FPM Seal Florocarbon) (V).
Plug - Nippel	:Stainless Steel - Edelstahl
Plug Back Part - Hinterteil Nippel	:Steel & galvanized - Stahl Verzinkt
Dust caps - Staubkappen	:Delrin & chloroprene

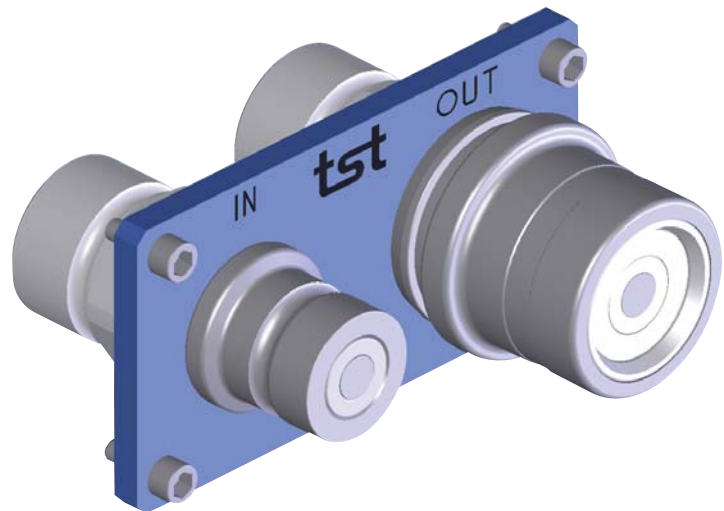
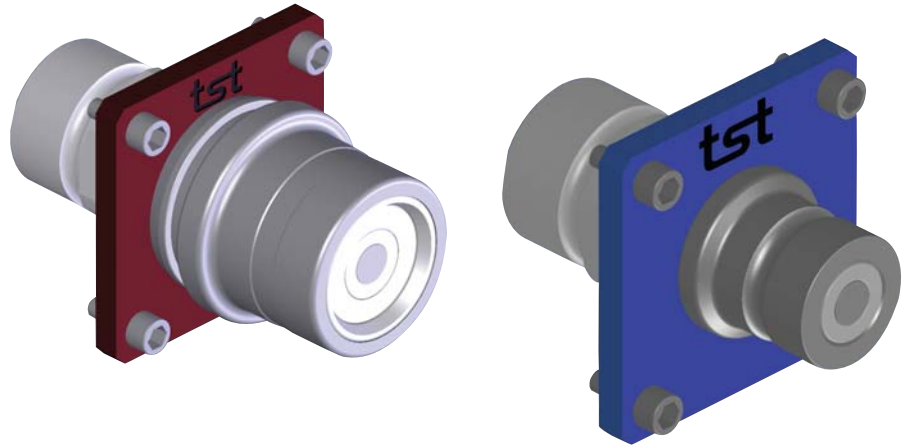

Applications

- High pressure hydraulic circuits.
- Connection of hydraulic pumps, valves and quick tool change.
- Aluminium die casting.
- Test benches.
- Plastic industry tool changing.
- Steel industry.

Specification

- Automatically one hand connection, disconnection.
- Flush face,
- Non spill.
- Ball locking type
- High pressure.
- High flow
- Colour code circuit definition.
- 4 different size (Ø6, Ø8, Ø12, Ø16)

Anwendungen

- Hochdruck-Hydraulikkreisläufe
- Verbindung von hydraulike Pumpen und Ventile für schnellen Werkzeugwechsel.
- Aluminiumdruckguss
- Prüfstände
- Werkzeugwechsel in der Kunststoffindustrie
- Stahlindustrie

Spezifikationen

- Ein- und Auskuppeln mit einer Hand.
- Ebene Stirnfläche
- Leckagefrei
- Kugelverriegelung
- Hochdruck
- Hoher Durchfluss
- Kennzeichnung von Flüssigkeitskreisläufen durch Farbringe
- 4 verschiedene Größen

COUPLINGS, MULTICOUPLINGS & MOULD COOLING PRODUCTS

KUPPLUNGEN, MULTIKUPPLUNGEN & KÜHLUNGSELEMENTE FÜR WERKZEUGE

SERIE 124



PK - Dust protection cover
PK - Schutzhülle Bezeichnung



Dust protection cover to protect entering contamination..) -
Gekapselte Ausführung verhindert das Eindringen von Verschmutzungen



PD - Max Residual Pressure chart (Bar)
PD - Restdruck (Bar)

Coupler and Plug Kupplung und Nippel	124.06	124.08	124.12	124.18
Coupler / Kupplung	-	150	150	150
Plugs / Nippel	40	90	35	60

Step - 1 According to the installation of system
If the residual pressure is on socket side drain container (Plug side) pressure should be zero (P=0)

Step - 2 According to the installation of system If the residual pressure is on socket side drain container (Socket side) pressure should be zero (P=0)
For the residual pressure optional orders please add PD end of the order no.

Schritt = 1 entsprechend der Installation des Systems
Wenn Restdruck an der Kupplungsseite anliegt, dann sollte die Gegenseite zum Tank (in diesem Fall Steckerseite) drucklos sein (P=0)

Schritt = 2 entsprechend der Installation des Systems
Wenn Restdruck an der Steckerseite anliegt, dann sollte die Gegenseite zum Tank (in diesem Fall Kupplungsseite) drucklos sein (P=0)
Für die Option Restdruckabbau fügen Sie bitte PD am Ende der Bestellnummer hinzu

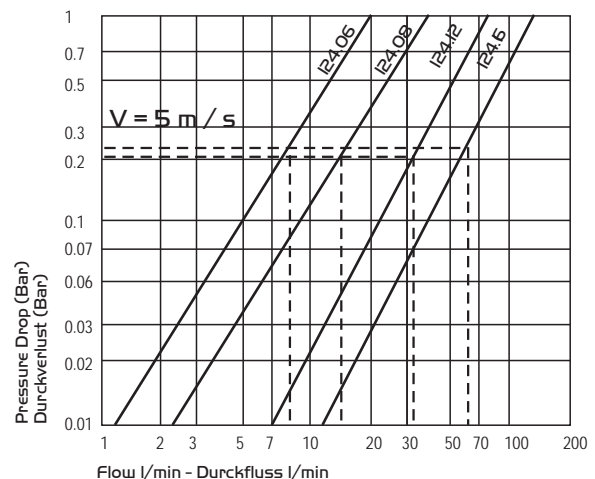



SERIE 124 ■

COUPLINGS, MULTICOUPLINGS & MOULD COOLING PRODUCTS

KUPPLUNGEN, MULTIKUPPLUNGEN & KÜHLUNGSELEMENTE FÜR WERKZEUGE



Coupler and Plug
Kupplung und Nippel

Size Nennweite	Connection Anschlüsse F	Order No / Bestellnr.	ØD	L	LI	L2	L3	SW
06	BSP 3/8"	124.06 DGB 17	39	77	69			27
	NPT 3/8"	124.06 NGB 17	39	75	67			27
	UNF 9/16"-18	124.06 UGB 14	39	77	69			27
08	BSP 1/2"	124.08 DGB 21	47	90.5	81.5			32
	NPT 1/2"	124.08 NGB 21	47	87.5	79			32
	UNF 3/4"-18	124.08 UGB 19	47	87.5	79			32
12	BSP 3/4"	124.12 DGB 26	59	103.5	93.5			41
	NPT 3/4"	124.12 NGB 26	59	99.5	89.5			41
	UNF 1.1/16"-12	124.12 UGB 27	59	104.5	94.5			41
16	BSP 3/4"	124.16 DGB 26	69	116.5	106			50
	NPT 3/4"	124.16 NGB 26	69	113.5	103			50
	UNF 1.5/16"-16	124.16 UGB 33	69	118.5	103			50

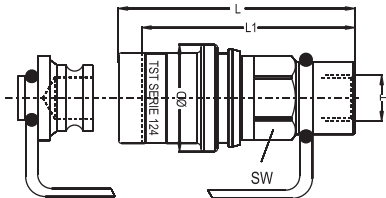

Female Threaded Socket
Kupplung mit Innengewinde

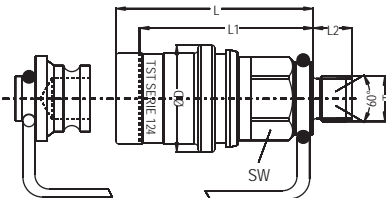

Male Threaded Socket
(60° Conn. & Conn. Sealing With O-ring)
Kupplung mit Aussengewinde mit 60° Dichtkonus

06	BSP 3/8"	124.06 EGB 17-60	39	66.5	58.5		12	27
08	BSP 1/2"	124.08 EGB 21-60	47	76.5	66.5		14	32
12	BSP 3/4"	124.12 EGB 26-60	59	90.5	78.5		16	41
16	BSP 3/4"	124.16 EGB 26-60	69	105	94.5		16	50

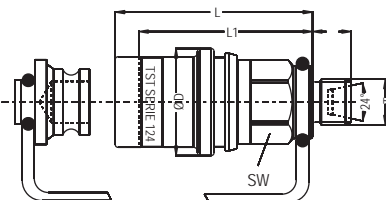

Male threaded sockets for hydraulic pipes with
24° taper according to ISO 8434-1 (TYPE: S)
Kupplung mit Außengewinde mit 24° Dichtkonus (TYP:S)

06	Ø10 (OD)	124.06 EGB 18-10	39	66.5	56.5	12		27
08	Ø12 (OD)	124.08 EGB 20-12	47	76.5	66.5	12		32
12	Ø16 (OD)	124.12 EGB 24-16	59	88.5	78.5	14		41
16	Ø20 (OD)	124.16 EGB 30-20	69	105	94.5	16		50

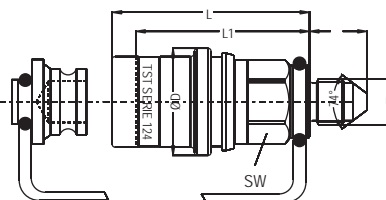

Male Threaded Socket (JIC 37 ISO 8434)
Kupplung mit Aussengewinde (JIC 37 ISO 8434)

06	UNF 1/2" 20-Ø5	124.06 JGB 27-74	39	64.5	56.5	14		27
08	UNF 3/4" 16-Ø8	124.08 JGB 27-74	47	74.5	66.5	16.7		32
12	UNF 7/8" 14-Ø10	124.12 JGB 27-74	59	88.5	78.5	19.3		41
16	UNF 1.1/16"-12" 12-Ø12	124.16 JGB 27-74	69	105	94.5	22		50

COUPLINGS, MULTICOUPLINGS & MOULD COOLING PRODUCTS

KUPPLUNGEN, MULTIKUPPLUNGEN & KÜHLUNGSELEMENTE FÜR WERKZEUGE

SERIE 124



**Coupler and Plug
Kupplung und Nippel**

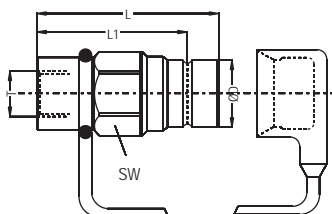

Female Threaded Plugs
Nippel mit Innengewinde

Size Nennweite	Connection Anschlüsse F	Order No / Bestellnr.	ØD	L	L1	L2	L3	SW
06	BSP 3/8"	124.06 DUB 17	30.5	62	51.5			27
	NPT 3/8"	124.06 NUB 17	30.5	60	49.5			27
	UNF 9/16"-18	124.06 UUB 14	30.5	62	51.5			27
08	BSP 1/2"	124.08 DUB 21	35.5	73	61			32
	NPT 1/2"	124.08 NUB 21	35.5	70.5	58.5			32
	UNF 3/4"-16	124.08 UUB 19	35.5	70.5	58.5			32
12	BSP 3/4"	124.12 DUB 26	46	84.5	68.5			41
	NPT 3/4"	124.12 NUB 26	46	80.5	64.5			41
	UNF 1.1/16"-12	124.12 UUB 27	46	85.5	69.5			41
16	BSP 3/4"	124.16 DUB 26	56.5	94.5	73			50
	NPT 3/4"	124.16 NUB 26	56.5	91.5	70			50
	UNF 1.5/16"-16	124.16 UUB 33	56.5	96.5	75			50

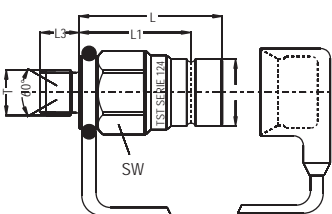

Male Threaded Plugs
(60° Conn. & Conn. Sealing With O-ring)
Nippel mit Außengewinde mit 60° Dichtkonus

06	BSP 3/8"	124.06 EUB 17-60	30.5	51.5	41	12		27
08	BSP 1/2"	124.08 EUB 21-60	35.5	59	47	14		32
12	BSP 3/4"	124.12 EUB 26-60	46	71.5	55.5	16		41
16	BSP 3/4"	124.16 EUB 26-60	56.5	83	61.5	16		50

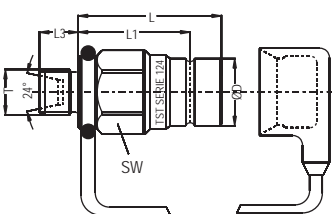

Male threaded Plugs for hydraulic pipes with
24° taper according to ISO 8434-1 (TYPE: S)
Nippel mit Außengewinde mit 24° Dichtkonus (TYP:S)

06	Ø10 (OD)	124.06 EUB M18-10	30.5	49.5	39	12		27
08	Ø12 (OD)	124.08 EUB M20-12	35.5	58	46	12		32
12	Ø16 (OD)	124.12 EUB M24-16	46	69.5	53.5	14		41
16	Ø20 (OD)	124.16 EUB M30-20	56.5	83	61.5	16		50

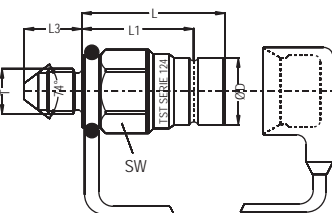

Male Threaded Plugs (JIC 37 ISO 8434)
Nippel mit Außengewinde mit 74° Dichtkegel

06	UNF 1/2" 20-Ø5	124.06 JUB 27-74	30.5	49.5	39	14		27
08	UNF 3/4" 16-Ø8	124.08 JUB 27-74	36	58	46	16.7		32
12	UNF 7/8" 14-Ø10	124.12 JUB 27-74	46	69.5	53.5	19.3		41
16	UNF 1.1/16-12" 12-Ø12	124.16 JUB 27-74	56.5	83	61.5	22		50

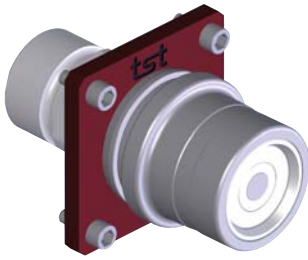

SERIE 124 ■

COUPLINGS, MULTICOUPLINGS & MOULD COOLING PRODUCTS

KUPPLUNGEN, MULTIKUPPLUNGEN & KÜHLUNGSELEMENTE FÜR WERKZEUGE



One Coupler On Mono Plate
Eine Kupplung auf der Monoplatte

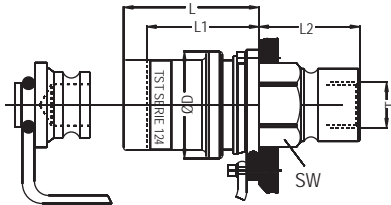

Female Threaded Socket
Kupplung mit Innengewinde

Size Nennweite	Connection Anschlüsse F	Order No / Bestellnr.	ØD	L	L1	L2	L3	SW
06	BSP 3/8"	1241.06 DGB 17	39	44	36			27
	NPT 3/8"	1241.06 NGB 17	39	44	36			27
	UNF 9/16"-18	1241.06 UGB 14	39	44	36			27
08	BSP 1/2"	1241.08 DGB 21	47	50	41.5			32
	NPT 1/2"	1241.08 NGB 21	47	50	41.5			32
	UNF 3/4"-18	1241.08 UGB 19	47	50	41.5			32
12	BSP 3/4"	1241.12 DGB 26	59	58	48.5			41
	NPT 3/4"	1241.12 NGB 26	59	58	48.5			41
	UNF 1.1/16"-12	1241.12 UGB 27	59	58	48.5			41
16	BSP 3/4"	1241.16 DGB 26	69	68	57.5			50
	NPT 3/4"	1241.16 NGB 26	69	68	57.5			50
	UNF 1.5/16"-16	1241.16 UGB 33	69	68	57.5			50

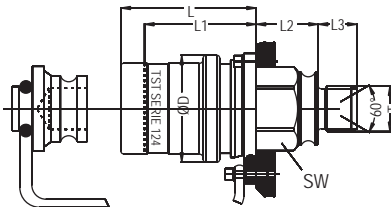

Male Threaded Socket
(60° Conn. & Conn. Sealing With O-ring)
Kupplung mit Aussengewinde mit 60° Dichtkonus

06	BSP 3/8"	1241.06 EGB 17-60	39	44	36	12		27
08	BSP 1/2"	1241.08 EGB 21-60	47	50	41.4	14		32
12	BSP 3/4"	1241.12 EGB 26-60	59	58	48.5	16		41
16	BSP 3/4"	1241.16 EGB 26-60	69	68	57.5	16		50

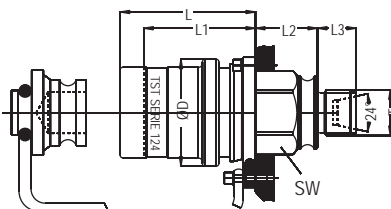

Male threaded sockets for hydraulic pipes with
24° taper according to ISO 8434-1 (TYPE: S)
Kupplung mit Außengewinde mit 24° Dichtkonus (TYP:S)

06	Ø10 (OD)	1241.06 EGB M18-10	39	44	36	12		27
08	Ø12 (OD)	1241.08 EGB M20-12	47	50	41.5	12		32
12	Ø16 (OD)	1241.12 EGB M24-16	59	58	48.5	14		41
16	Ø20 (OD)	1241.16 EGB M30-20	69	68	57.5	16		50

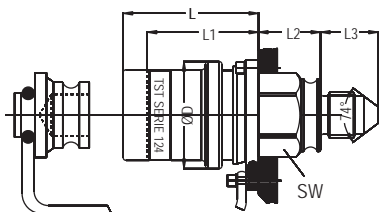

Male Threaded Socket (JIC 37 ISO 8434)
Kupplung mit Aussengewinde (JIC 37 ISO 8434)

06	UNF 1/2" 20-Ø5	1241.06 JGB 27-74	39	44	36	14		27
08	UNF 3/4" 16-Ø8	1241.08 JGB 27-74	47	50	41.5	16.7		32
12	UNF 7/8" 14-Ø10	1241.12 JGB 27-74	59	58	48.5	19.3		41
16	UNF 1.1/16"-12" 12-Ø12	1241.16 JGB 27-74	69	68	57.5	22		50

COUPLINGS, MULTICOUPLINGS & MOULD COOLING PRODUCTS

KUPPLUNGEN, MULTIKUPPLUNGEN & KÜHLUNGSELEMENTE FÜR WERKZEUGE

SERIE 124

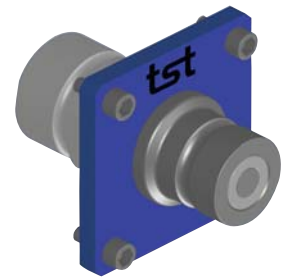

**One Coupler On Mono Plate
Eine Kupplung auf der Monoplatte**

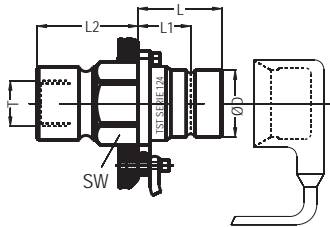

Female Threaded Plugs
Nippel mit Innengewinde

Size Nennweite	Connection Anschlüsse F	Order No / Bestellnr.	ØD	L	LI	L2	L3	SW
06	BSP 3/8"	1241.06 DUB 17		29	18.5	33		27
	NPT 3/8"	1241.06 NUB 17		29	18.5	31		27
	UNF 9/16"-18	1241.06 UUB 14		29	18.5	33		27
08	BSP 1/2"	1241.08 DUB 21		33	21	40.5		32
	NPT 1/2"	1241.08 NUB 21		33	21	38		32
	UNF 3/4"-16	1241.08 UUB 19		33	21	38		32
12	BSP 3/4"	1241.12 DUB 26		39.5	23.5	45.5		41
	NPT 3/4"	1241.12 NUB 26		39.5	23.5	41.5		41
	UNF 1.1/16"-12	1241.12 UUB 27		39.5	23.5	46.5		41
16	BSP 3/4"	1241.16 DUB 26		46	24.5	48.5		50
	NPT 3/4"	1241.16 NUB 26		46	24.5	45.5		50
	UNF 1.5/16"-16	1241.16 UUB 33		46	24.5	50.5		50

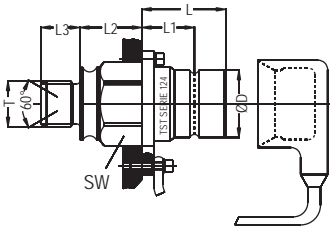

Male Threaded Plugs
(60° Conn. & Conn. Sealing With O-ring)
Nippel mit Außengewinde mit 60° Dichtkonus

06	BSP 3/8"	1241.06 EUB 17-60		29	18.5	23	12	27
08	BSP 1/2"	1241.08 EUB 21-60		33	21	26.5	14	32
12	BSP 3/4"	1241.12 EUB 26-60		39.5	23.5	32.5	16	41
16	BSP 3/4"	1241.16 EUB 26-60		46	37	37	16	50

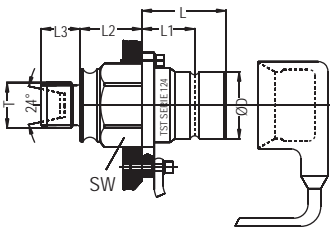

Male threaded Plugs for hydraulic pipes with
24° taper according to ISO 8434-1 (TYPE: S)
Nippel mit Außengewinde mit 24° Dichtkonus (TYP:S)

06	Ø10 (OD)	1241.06 EUB M18-10		29	39	21	12	27
08	Ø12 (OD)	1241.08 EUB M20-12		33	46	21	14	32
12	Ø16 (OD)	1241.12 EUB M24-16		39.5	53.5	30.5	16	41
16	Ø20 (OD)	1241.16 EUB M30-20		24.5	61.5	37	16	50

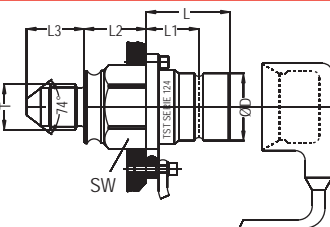

Male Threaded Plugs (JIC 37 ISO 8434)
Nippel mit Außengewinde (JIC 37 ISO 8434)

06	UNF 1/2" 20-Ø5	1241.06 JUB 27-74		29	39	21	14	27
08	UNF 3/4" 16-Ø8	1241.08 JUB 27-74		33	46	21	16.7	32
12	UNF 7/8" 14-Ø10	1241.12 JUB 27-74		39.5	53.5	30.5	19.3	41
16	UNF 1.1/16-12" 12-Ø12	1241.16 JUB 27-74		24.5	61.5	37	22	50

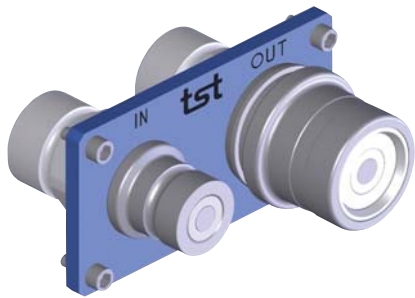

SERIE 124 ■

COUPLINGS, MULTICOUPLINGS & MOULD COOLING PRODUCTS

KUPPLUNGEN, MULTIKUPPLUNGEN & KÜHLUNGSELEMENTE FÜR WERKZEUGE



One Coupler & One Plug On Twin Plate
Ein Kupplung und eine Nippel auf der Duoplatte

Size Nennweite	Connection Anschlüsse F	Order No / Bestellnr.	ØD	L	L1	L2	L3	SW
06	BSP 3/8"	1241.06 DGUB 17		44	36	33		27
	NPT 3/8"	1241.06 NGUB 17		44	36	31		27
	UNF 9/16"-18	1241.06 UGUB 14		44	36	33		27
08	BSP 1/2"	1241.08 DGUB 21		50	41.5	40.5		32
	NPT 1/2"	1241.08 NGUB 21		50	41.5	38		32
	UNF 3/4"-18	1241.08 UGUB 19		50	41.5	38		32
12	BSP 3/4"	1241.12 DGUB 26		58	48.5	45.5		41
	NPT 3/4"	1241.12 NGUB 26		58	48.5	41.5		41
	UNF 1.1/16"-12	1241.12 UGUB 27		58	48.5	46.5		41
16	BSP 3/4"	1241.16 DGUB 26		68	57.5	48.5		50
	NPT 3/4"	1241.16 NGUB 26		68	57.5	45.5		50
	UNF 1.5/16"-16	1241.16 UGUB 33		68	57.5	50.5		50

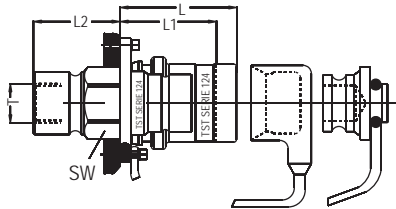

Female Threaded Socket & Plug
Kupplung und Nippel mit Innengewinde

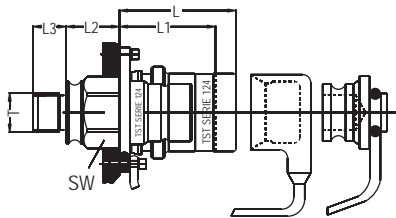

Male Threaded Socket & Plug
(60° Conn. & Conn. Sealing With Oring)
Kupplung und Nippel mit Außengewinde
mit 60° Dichtkonus

06	BSP 3/8"	1241.06 EGUB 17-60		44	36	22.5	12	27
08	BSP 1/2"	1241.08 EGUB 21-60		50	41.4	26.5	12	32
12	BSP 3/4"	1241.12 EGUB 26-60		58	48.5	32.5	14	41
16	BSP 3/4"	1241.16 EGUB 26-60		68	57.5	37	16	50

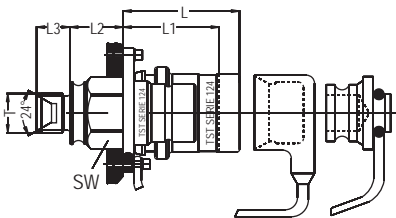

Male threaded sockets for hydraulic pipes with
24° taper according to ISO 8434-1 (TYPE: S)
Kupplung mit Außengewinde mit 24° Dichtkonus (TYP:S)

06	Ø10 (OD)	1241.06 EGUB M18-10		44	36	20.5	12	27
08	Ø12 (OD)	1241.08 EGUB M20-12		50	41.5	25.5	12	32
12	Ø16 (OD)	1241.12 EGUB M24-16		58	48.5	30.5	14	41
16	Ø20 (OD)	1241.16 EGUB M30-20		68	57.5	37	16	50

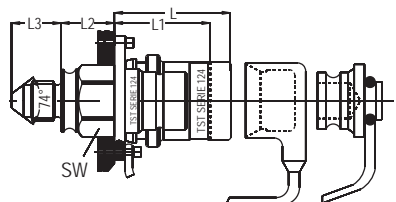

Male Threaded Socket & Plug (JIC 37 ISO 8434)
Kupplung und Nippel mit Außengewinde
(JIC 37 ISO 8434)

06	UNF 1/2" 20-Ø5	1241.06 JGUB 27-74		44	36	20.5	14	27
08	UNF 3/4" 16-Ø8	1241.08 JGUB 27-74		50	41.5	25.5	16.7	32
12	UNF 7/8" 14-Ø10	1241.12 JGUB 27-74		58	48.5	30.5	19.3	41
16	UNF 1.1/16"-12" 12-Ø12	1241.16 JGUB 27-74		68	57.5	37	22	50

COUPLINGS, MULTICOUPLINGS & MOULD COOLING PRODUCTS

KUPPLUNGEN, MULTIKUPPLUNGEN & KUHLUNGSELEMENTE FÜR WERKZEUGE

■ SERIE 124



Mono Plate / Monoplatte

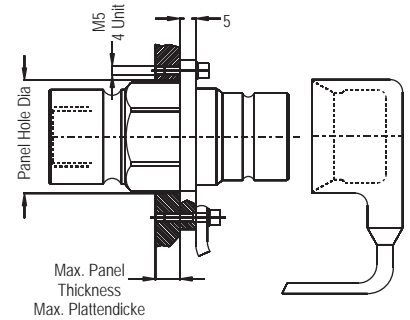
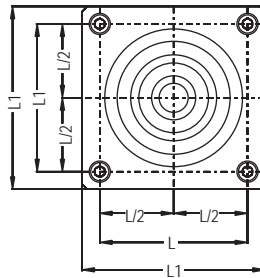
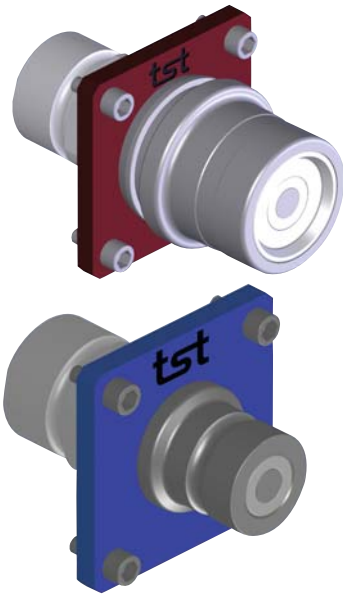

Serie	Max. Panel Thickness Max. Plattendicke	Panel Hole Plattenbohrung	L	LI
124.06	8	32	39	50
124.08	10	37.5	40	53
124.12	10	48	52	65
124.16	10	58	57	70

Twin Plate / Duo Platte

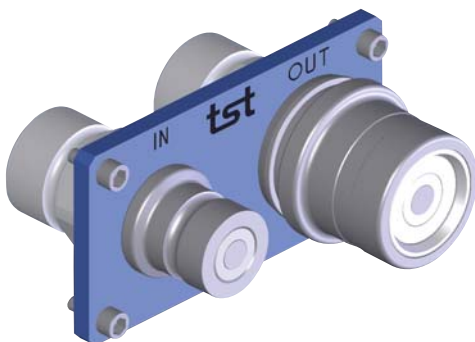
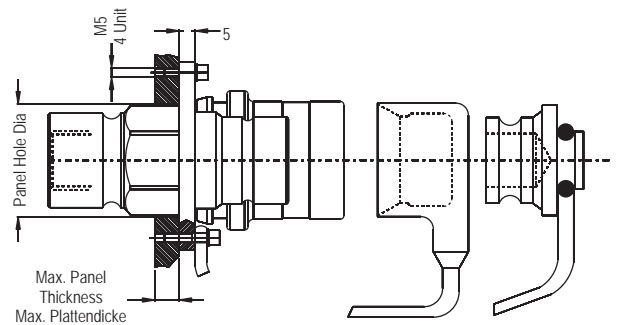
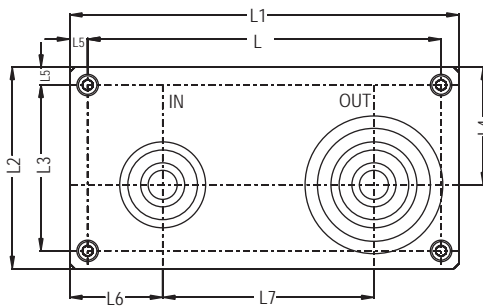

Serie	Max. Panel Thickness Max. Plattendicke	Panel Hole Plattenbohrung	L	LI	L2	L3	L4	L5	L6	L7
124.06	8	32	84	95	53	42	29.5	5.5	23.5	48
124.08	10	37.5	97	110	63	50	36.5	6.5	26	58
124.12	10	48	122	135	75	62	42.5	6.5	32.5	70
124.16	10	58	137	150	80	67	45	6.5	35	80