

MINIATURE MONO RAIL

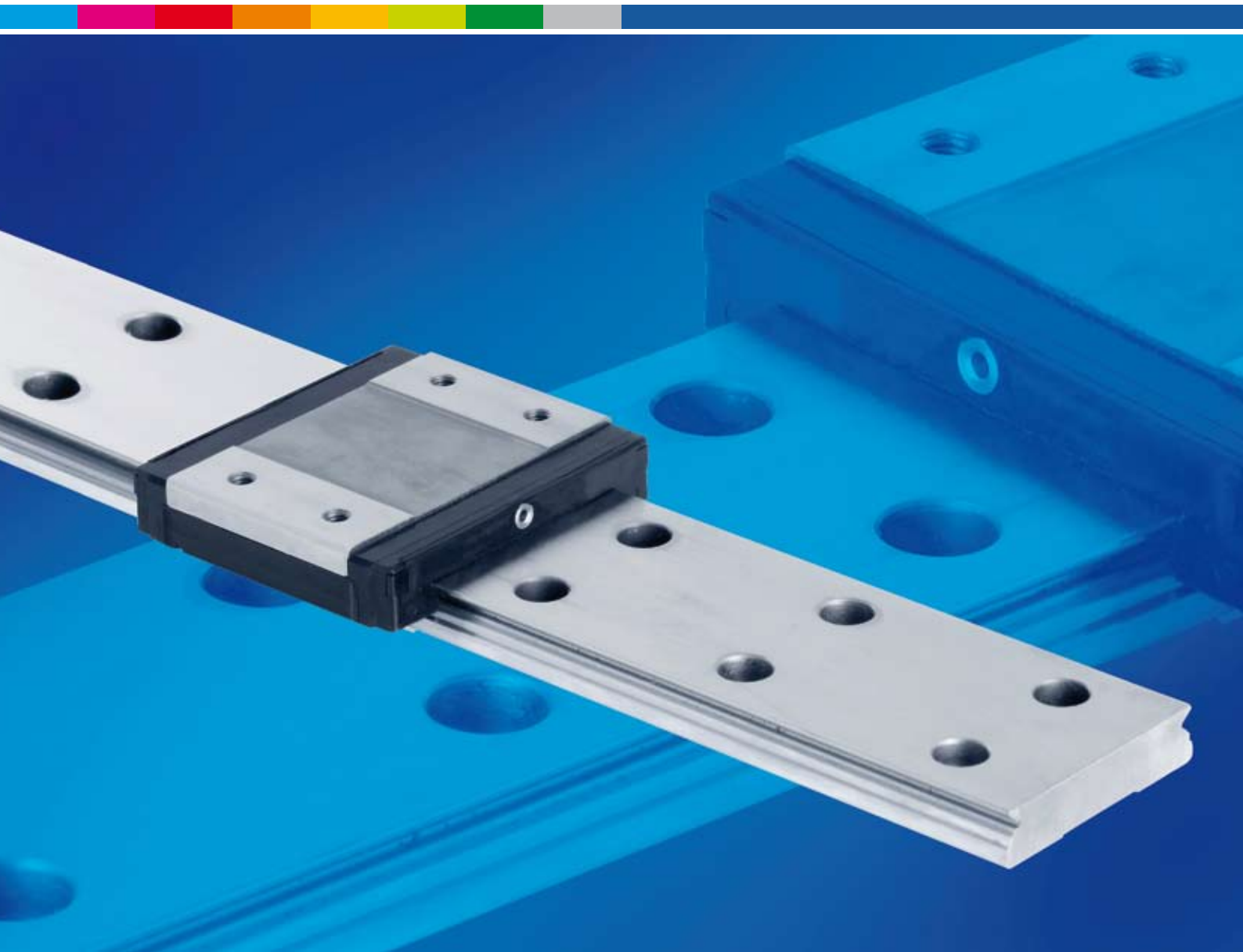

About Rollon



Development of global business

- 1975** Parent company, Rollon S.r.l., founded in Italy
- 1991** Founding of Rollon GmbH in Germany
- 1995** Expansion of headquarters to new 4,000 m² factory
Assembly starts in Germany
Quality management certified to ISO 9001
- 1998** Rollon B.V. in the Netherlands and Rollon Corporation in the USA are founded
Expansion of German branch to new 1,000 m² plant
- 1999** Founding of Rollon S.A.R.L. in France
Environmental management certified to ISO 14001
- 2000** Rollon s.r.o. founded in Czech Republic
- 2001** Expansion of headquarters to new 12,000 m² manufacturing plant
- 2007** Restructuring of the GmbH and alignment of production in Germany to customer-specific adaptations
Takeover of the assets of a manufacturer of linear rail systems
- 2008** Expansion of sales network in Eastern Europe and Asia

Continual expansion and optimization of the portfolio

Founded in 1975, Rollon manufactured high-precision linear roller bearings for the machine tool industry. Soon Rollon started manufacturing linear bearings based on the roller-cage. In 1979, Compact Rail self-aligning linear bearings joined Telescopic Rail industrial drawer slides and Easy Rail linear bearings. These products became the strong foundation on which the company is built today. Continuous optimisation of these core products remains one of the most important jobs at Rollon.

The patented Compact Rail linear bearing, which uses different proprietary rail profiles and high-precision, radial ball bearing sliders, enables compensation of height and angle mounting defects in applications and is only one example for the continuing innovative development of the existing product program.

In the same manner, we continually introduce innovative new product families emphasizing our continuing product development and optimization. These include:

- 1994 Light Rail - full and partial extensions in lightweight design
- 1996 Uniline - belt driven linear actuators
- 2001 Ecoline - aluminum economical linear system
- 2002 X-Rail - inexpensive formed steel linear bearings
- 2004 Curviline - curvilinear rails and the monorail profile rail guide
- 2007 Monorail miniature sizes

Each expansion of the product range is built on the experience of today's total of nine product families and is based on market demands. Linear technology for any application from Rollon, the total supplier.

Content

1 Product explanation	
Mono Rail Miniature Profile Rails	4
2 Technical data	
Performance characteristics and remarks	6
Load capacities	7
3 Product dimensions	
Standard width	8
Large width	9
4 Technical instructions	
Precision	10
Preload, Lubrication	11
Friction, Seal	13
Loading	14
Service life	16
Installation instructions	17

Ordering key

Ordering key with explanations and hole pattern

Portfolio

Product explanation

Mono Rail Miniature are profile rails with two-row recirculating balls



Fig. 1

The running grooves are ground in gothic arch profile and have a contact angle of 45° so that the same load capacity is guaranteed in all principle directions. Use of large steel balls enables high load and moment capacities despite limited available space.

The most important characteristics:

- Unique ball return circulation
- Integrated ball reverse for improved running properties and increased speeds
- Corrosion resistant
- Mono Rail Miniature profile rails have stable and constantly uniform displacement resistance and require a low breakaway force
- Mono Rail Miniature profile rails are equipped with efficient end seals on both sides of the carriage
- High system rigidity

Preferred areas of application of the Mono Rail Miniature product family:

- Medical technology
- Semi-conductor and electronic industry
- Construction and machine technology
(e.g., Pick-and-Place multi-axis systems)

Standard width

Compact technology and high performance in its smallest structural shape.



Fig. 2

Large width

Wide miniature profile rails, with a compact size, allow the acceptance of higher forces and moments. Especially suited for single rail applications.



Fig. 3

Unique ball return circulation

The return channels and redirection for the stainless steel balls are made completely out of plastic. The efficient design principle reduces contact between the balls and the metal body. This in turn reduces the generation of noise du-

ring operation. The well-thought-out lubricating principle with lubricant reservoir integrated in the ball recirculation increases the time between lubrication intervals.

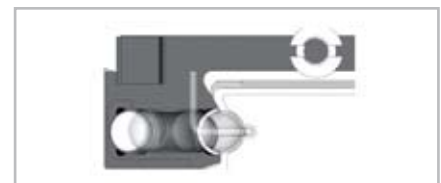

Fig.4

Integrated redirection

During the carriage movements, the plastic end caps are subjected to permanent shocks caused by the continuous change of direction of movement. These shock loads have a critical influence on the running properties and speed.

Automation and production demands of modern industry call for high operating speeds. The integrated ball redirection, i.e., the direct connection of ball redirection and body, creates an optimum solution for the miniature profile rails.

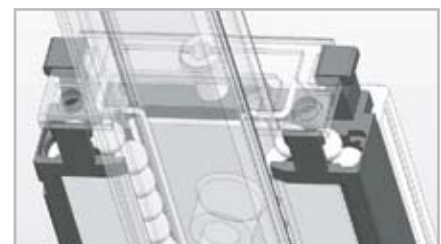

Fig.5

Technical data



Fig. 6

Performance characteristics:

- Available sizes of standard width: 7, 9, 12, 15
- Available sizes of large width: 9, 12, 15
- More sizes on request
- Max. operating speed:
3 m/s (118 in/s) (depending on application)
- Max. acceleration:
250 m/s² (9,844 in/s²) (depending on application)
- Temperature range: -40 °C to +80 °C (-40 °F to +176 °F),
temporary temperature peaks are possible up to +100 °C (+212 °F)
- Available single rail lengths up to 1,000 mm (39.37 in)
- Three preload classes: V₀, V_S, V₁
- Three precision classes: P, H, N
- Gothic arch profile with 45° contact angle for the same load capacity
in all principle directions
- Corrosion resistant steel

Remarks:

- Combining rails is possible (joining)
- Alternative rail fixing possible on request

Load capacities

Standard width

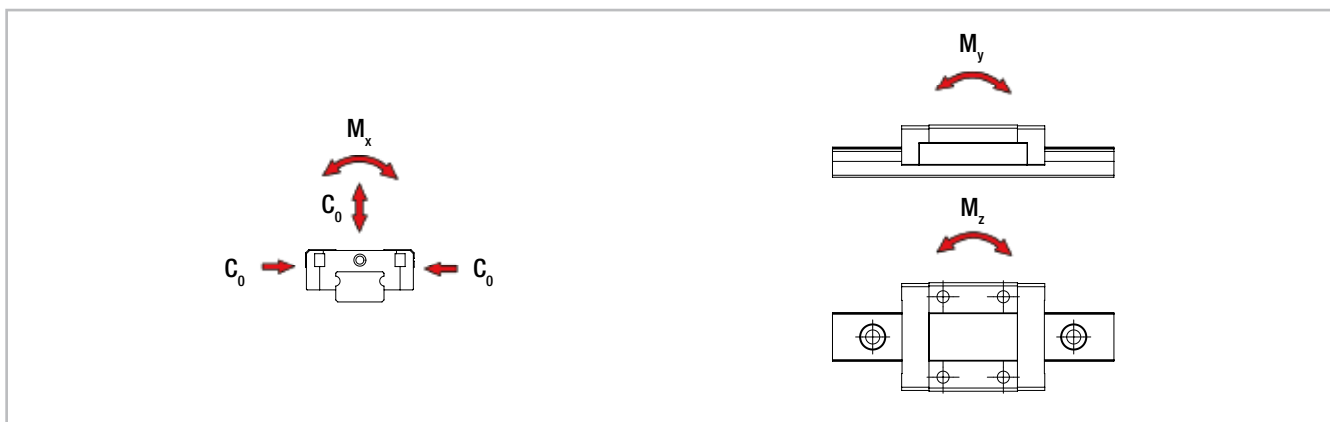

Fig. 7

Type	Load capacities [N]		Static moments [Nm]		
	dyn. C_{100}	stat. C_0	M_x	M_y	M_z
MR07MN	890	1400	5.2	3.3	3.3
MR09MN	1570	2495	11.7	6.4	6.4
MR12MN	2308	3465	21.5	12.9	12.9
MR15MN	3810	5590	43.6	27	27

Tab. 1

Large width

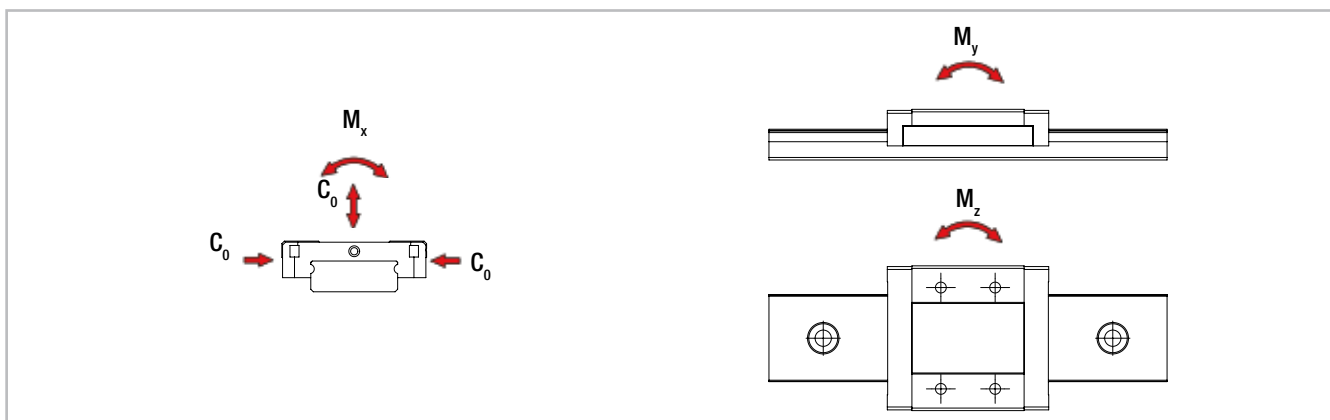

Fig. 8

Type	Load capacities [N]		Static moments [Nm]		
	dyn. C_{100}	stat. C_0	M_x	M_y	M_z
MR09WN	2030	3605	33.2	13.7	13.7
MR12WN	3065	5200	63.7	26.3	26.3
MR15WN	5065	8385	171.7	45.7	45.7

Tab. 2

Product dimensions

Standard width

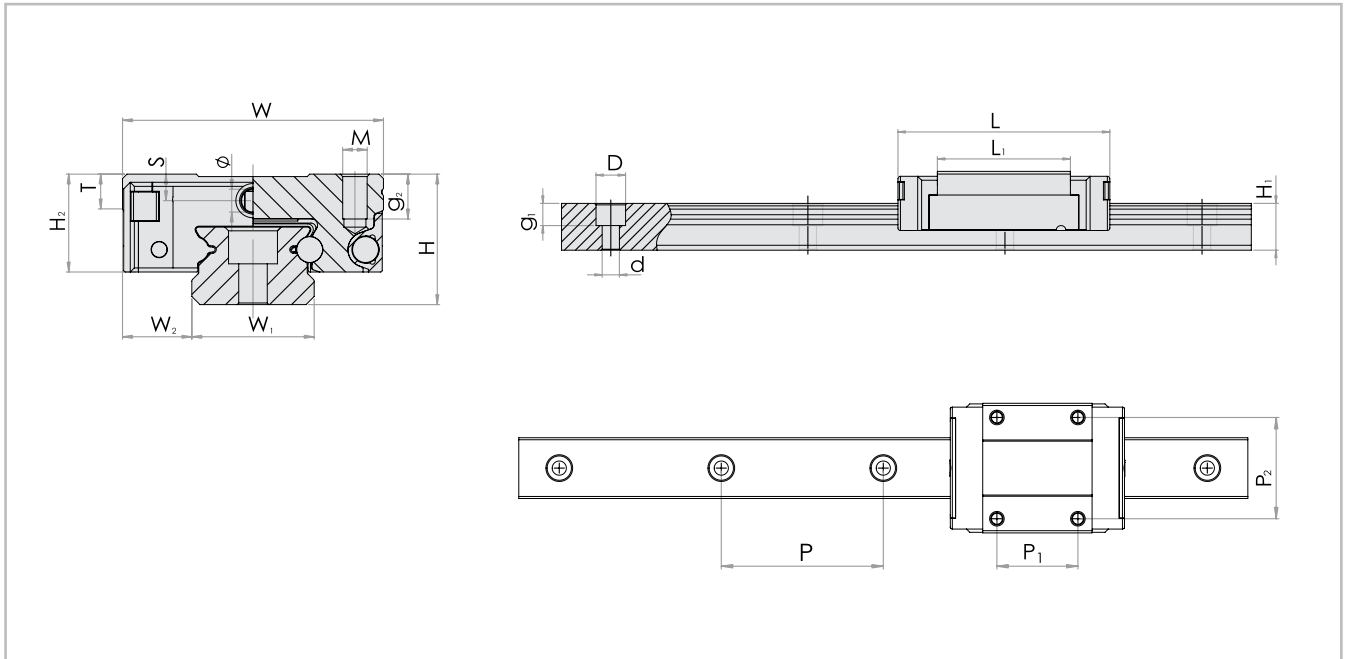

Fig. 9

Type	System [mm]			
	H	W	W ₂	H ₂
MR07MN	8	17	5	6.5
MR09MN	10	20	5.5	7.8
MR12MN	13	27	7.5	10
MR15MN	16	32	8.5	12

Tab. 3

Type	Slider [mm]										Rail [mm]						
	L	P ₂	P ₁	M	g ₂	L ₁	T	S	Ø	Weight [kg]	W ₁	H ₁	P	d	D	g ₁	Weight [kg/m]
MR07MN	23.7	12	8	M2	2.5	14.3	2.8	1.6	1.1	0.008	7	4.7	15	2.4	4.2	2.3	0.215
MR09MN	30.6	15	10	M3	3.0	20.5	3.3	2.2	1.3	0.018	9	5.5	20	3.5	6	3.5	0.301
MR12MN	35.4	20	15	M3	3.5	22.0	4.3	3.2	1.3	0.034	12	7.5	25	3.5	6	4.5	0.602
MR15MN	43.0	25	20	M3	5.5	27.0	4.3	3.3	1.8	0.061	15	9.5	40	3.5	6	4.5	0.93

Tab. 4

Large width

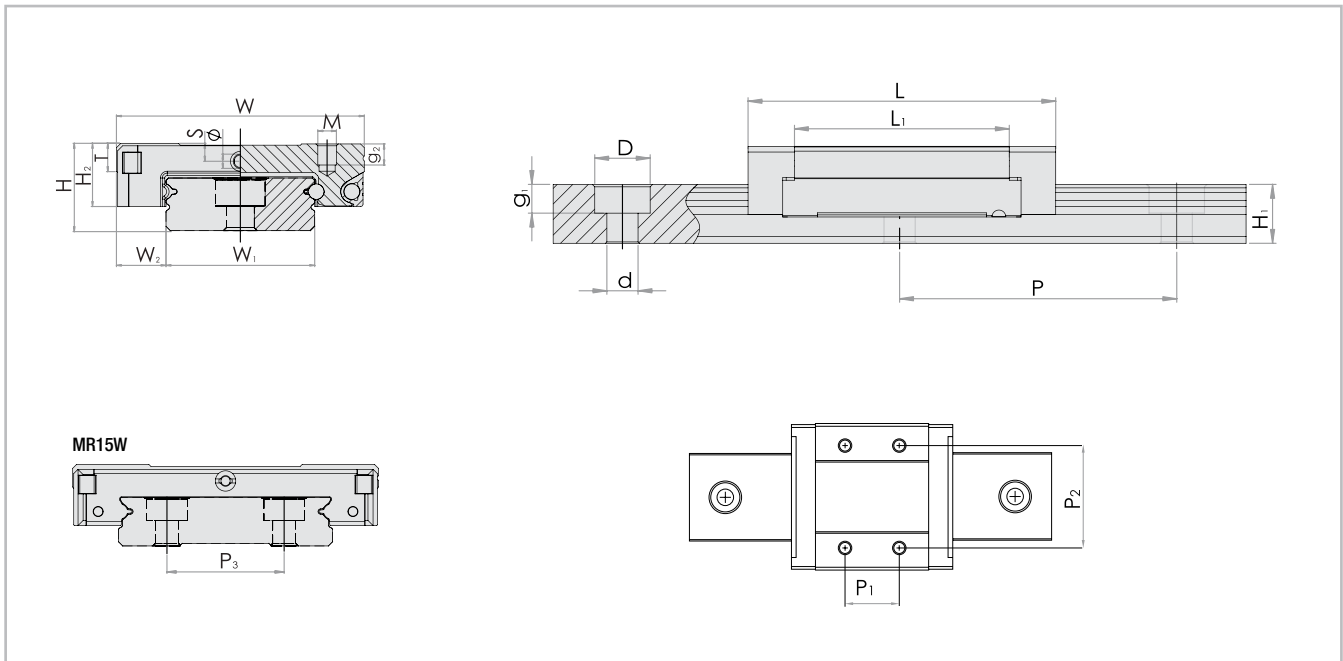

Fig. 10

Type	System [mm]			
	H	W	W ₂	H ₂
MR09WN	12	30	6	8.6
MR12WN	14	40	8	10.1
MR15WN	16	60	9	12

Tab. 5

Type	Slider [mm]										Rail [mm]							
	L	P ₂	P ₁	M	g ₂	L ₁	T	S	Ø	Weight [kg]	W ₁	H ₁	P	P ₃	d	D	g ₁	Weight [kg/m]
MR09WN	39.1	21	12	M3	3	27.9	4	2.6	1.3	0.037	18	7.3	30	-	3.5	6		0.94
MR12WN	44.4	28	15	M3	3.5	31.0	4.5	3.1	1.3	0.065	24	8.5	40	-	4.5	8	4.5	1.472
MR15WN	55.3	45	20	M4	4.5	38.5	4.5	3.3	1.8	0.137	42	9.5	40	23	4.5	8		2.818

Tab. 6

Technical instructions

Precision

There are three precision classes to choose from for the Mono Rail Miniature profile rails: Classes P, H, and N are manufactured.

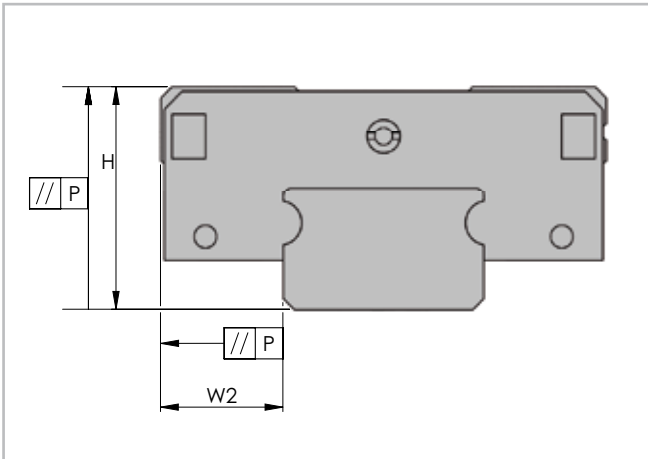

Fig. 11

	Precision classes	Precision P [μm]	High H [μm]	Normal N [μm]
H	Tolerance of height H	± 10	± 20	± 40
ΔH	Permissible height difference of different carriages at the same position on the rail	7	15	25
W ₂	Tolerance of width W ₂	± 15	± 25	± 40
ΔW ₂	Permissible width difference of different carriages at the same position on the rail	10	20	30

Tab. 7

Running accuracy

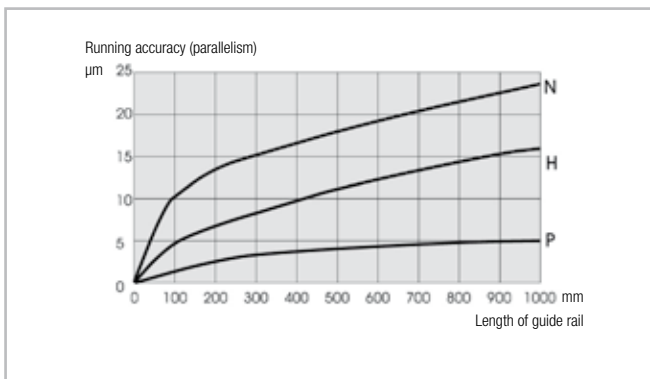

Fig. 12

Preload

The Mono Rail Miniature profile rails are available in the three different preload classes V_0 , V_s and V_1 (see table 8). The preload influences the rigidity, precision and torque resistance and also affects the product service life and displacement force.

Type	Preload classes		
	Small clearance Very quiet running V_0 [µm]	Standard Very quiet and precise running V_s [µm]	Small preload High rigidity, vibration reduced, high precision, good load balance V_1 [µm]
MR07	+4 to +2	+2 to 0	0 to -3
MR09	+4 to +2	+2 to 0	0 to -4
MR12	+5 to +2	+2 to 0	0 to -5
MR15	+6 to +3	+3 to 0	0 to -6

Tab. 8

Lubrication

Function

The contact points between ball and track are separated from each other by a microscopically thin oil film. The lubrication effects:

- Reduction of friction
- Reduction of wear
- Corrosion protection
- Better thermal distribution and therefore increased of service life

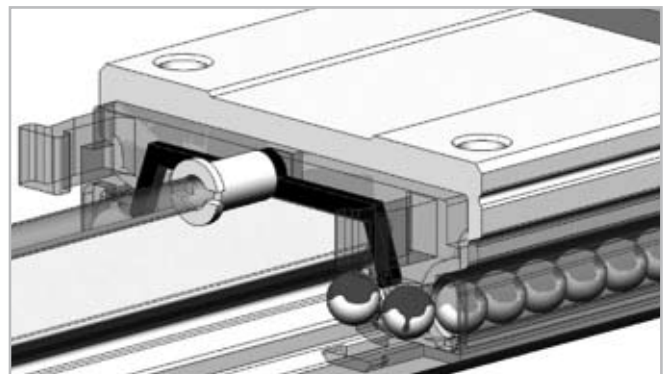

Fig. 13

Important instructions for lubrication

- Mono Rail Miniature profile rails must be lubricated for operation.
- The carriage must be moved back and forth during lubrication.
- The lubricant can also be applied to the tracks.
- The lubricant can be injected into the lubrication holes on both sides of the carriage.
- There should be a thin film of lubricant on the rail surface at all times.
- Please inform us in advance if the guides are to be used in acid or base containing environments or in clean rooms.
- Please contact the sales department if the oil lubrication should be used for vertical use of the guide.
- If the stroke is < 2 or > 15 times the carriage length, the lubrication intervals should be more often.

Grease lubrication

When using grease lubrication, we recommend synthetic-oil based lithium grease with a viscosity according to ISO VG 32-100.

Oil lubrication

We recommend CLP or CGLP synthetic oil conforming to DIN 51517 or HLP to DIN 51524 and a viscosity range conforming to ISO VG32-100 for operating temperatures between 0 °C and +70 °C. We recommend a viscosity according to ISO VG 10 for use at low temperatures.

For application-specific special lubrication please contact the sales department.

Relubrication

- Relubrication of the system must be done before the lubricant used is dirty or shows discolouration.
- An application of approx. 50 % of the quantity used for first lubrication is sufficient for relubrication (see tab. 9f).
- Relubrication is performed at operating temperature.
During relubrication, the carriage should be moved back and forth.
- If the stroke is < 2 or > 15 times the carriage length, the lubrication intervals should be more often.

Type	First lubrication [cm ³]
MR07MN	0.12
MR09MN	0.23
MR12MN	0.41
MR15MN	0.78

Tab. 9

Type	First lubrication [cm ³]
MR09WN	0.30
MR12WN	0.52
MR15WN	0.87

Tab. 10

Lubrication intervals

Operating speed, stroke length and ambient conditions influence the selection of time between lubrication intervals. Establishing a safe lubrication interval is based exclusively on the experienced practiced values determined on site. However, a lubrication interval should not be longer than one year in any case.

Friction

The Mono Rail Miniature profile rails have a low friction characteristic with constant running resistance and low breakaway force.

Causes of friction

- Friction of the sealing system
- Friction of the balls with each other
- Friction between balls and redirection
- Rolling resistance of the balls in the gothic arch running grooves
- Resistance of lubricant in the carriage
- Resistance by contamination in the lubricant

Friction with lubricated end seal

Type	M [N _{max}]	W [N _{max}]
MR07	0.1	-
MR09	0.1	0.8
MR12	0.4	1.0
MR15	1.0	1.0

Tab. 11

$$F_m = \mu \cdot F$$

F = load (N)

F_m = friction force (N)

Fig. 14

Mono Rail Miniature profile rails have a coefficient of friction of approx. $\mu = 0.002 - 0.003$.

Seal

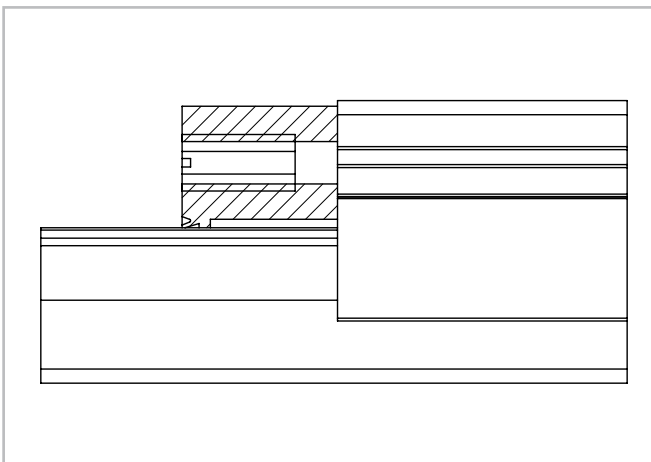

Fig. 15

The carriages of the Miniature Mono Rail are equipped with end seals on both sides.

The design of the end seal ensures a good and dust-proof seal. This extends the product service life, reduces the loss of lubricant and guarantees the optimum system lubrication over a long time.

The special design of the stripper allows a low seal resistance and has no negative influence on the running behaviour of the system.

Loading

Static load (P_0) and static moment (M_0)

Permissible static load

The permissible static load of the Mono Rail Miniature profile rail is limited by:

- Static load of each linear guide
- Permissible load of the fixing screws
- Permissible load of all components used in the surrounding construction
- Static safety factor, which is required by the corresponding application

The equivalent static load and the static moment are the largest load, or the largest moment, which are calculated based on formulas 3 and 4.

Static load capacity C_0

The static load capacity C_0 of ball recirculating guides is defined according to DIN 636, Part 2 as the only load which gives a Hertzian stress of 4,200 MPa with the existing lubrication between track and balls in the center of the highest loaded contact surface.

Note: In the loading center, there is a permanent deformation of approx 0.01 % of the ball diameter under this load (according to DIN 636, Part 2).

Static safety factor S_0

When observing the static safety factor S_0 the Mono Rail Miniature profile rails allow a permissible operation and high running precision as is required for each application. Calculation of the static safety factor S_0 ; see fig. 16

S_0 static safety factor

C_0 static load capacity in loading direction (N)

P_0 equivalent static load (N)

M_0 static moment in loading direction (Nm)

M equivalent static moment in loading direction (Nm)

$S_0 = C_0 / P_0$	Formula 1	Operating conditions	S_0
$S_0 = M_0 / M$	Formula 2	Normal operation	1 ~ 2
$P_0 = F_{max}$	Formula 3	Loading with vibration or shock effect	2 ~ 3
$M_0 = M_{max}$	Formula 4	High precision and smooth running	≥ 3

Fig. 16

Dynamic load capacity C

If the dynamic loads work vertically on the last zones with equal size and direction, the calculated service life of the linear guide can theoretically reach 100 km piston travel (as per DIN 636, Part 2).

Combined loads in combination with moments

If both loads and moments work on the profile rails, the equivalent dynamic load is calculated with formula 9. According to DIN 636, Part 1, the equivalent load should not exceed $\frac{1}{2} C$.

Equivalent dynamic load and speed

With changing load and speed, these must be considered individually since each parameter helps determine the service life.

Equivalent dynamic load

If only the load changes, the equivalent dynamic load can be calculated with formula 5.

Equivalent speed

If only the speed changes, the equivalent speed is calculated with formula 6.

If speed and load change, the equivalent dynamic load is calculated with formula 7.

Combined dynamic load

With combined exterior load in an arbitrary angle, the equivalent dynamic load is calculated with formula 8.

$$P = 3\sqrt{\frac{q_1 \cdot F_1^3 + q_2 \cdot F_2^3 + \dots + q_n \cdot F_n^3}{100}} \quad \text{Formula 5}$$

$$\bar{v} = \frac{q_1 \cdot v_1 + q_2 \cdot v_2 + \dots + q_n \cdot v_n}{100} \quad \text{Formula 6}$$

$$P = 3\sqrt{\frac{q_1 \cdot v_1 \cdot F_1^3 + q_2 \cdot v_2 \cdot F_2^3 + \dots + q_n \cdot v_n \cdot F_n^3}{100}} \quad \text{Formula 7}$$

$$P = |F_x| + |F_y| \quad \text{Formula 8}$$

$$P = |F_x| + |F_y| + \left(\frac{|M_x|}{M_x} + \frac{|M_y|}{M_y} + \frac{|M_z|}{M_z} \right) \cdot C_0 \quad \text{Formula 9}$$

P	= equivalent dynamic load (N)
q	= stroke (in %)
F ₁	= individual load levels (N)
v	= average speed (m/min)
\bar{v}	= individual speed levels (m/min)
F	= external dynamic load (N)
F _y	= external dynamic load – vertical (N)
F _x	= external dynamic load – horizontal (N)
C ₀	= static load capacity (N)
M ₁ , M ₂ , M ₃	= external moments (Nm)
M _x , M _y , M _z	= maximum permissible moments in the different loading directions (Nm)

Fig. 17

Service life

An example of a profile rail or a lot of identical profile rails under the same running conditions, which use ordinary materials with normal manufacturer's quality and operating conditions, can reach 90 % of the calculated service life (as per DIN 636 Part 2). By taking 50 km traverse as a basis, the dynamic load capacity is usually 20 % over the values as per DIN. The relationship between the two load capacities can be seen from formulas 10 and 11.

Calculation of service life

Formulas 12 and 13 are used for calculating the service life, if equivalent dynamic load and average speed are constant.

$C_{(50)} = 1,26 \cdot C_{(100)}$	Formula 10	L = service life based on 100,000 (m) L _h = service life (h) C = dynamic load capacity (N) P = equivalent dynamic load (N) S = stroke length (m) n = stroke frequency (min ⁻¹) V _m = average speed (m/min)
$C_{(100)} = 0,79 \cdot C_{(50)}$	Formula 11	
$L = \left(\frac{C_{100}}{P}\right)^3 \cdot 10^5$	Formula 12	
$L_h = \frac{L}{2 \cdot s \cdot n \cdot 60} = \frac{L}{V_m} \cdot \left(\frac{C_{100}}{P}\right)^3$	Formula 13	

Fig. 18

Installation instructions

Shoulder heights and radius of stop edges

Rounding of the stop edges of the surrounding construction should be made so as to avoid contact with the edges of the carriage and the rail. Please observe the following table with the information on the radius and height of the stop surfaces.

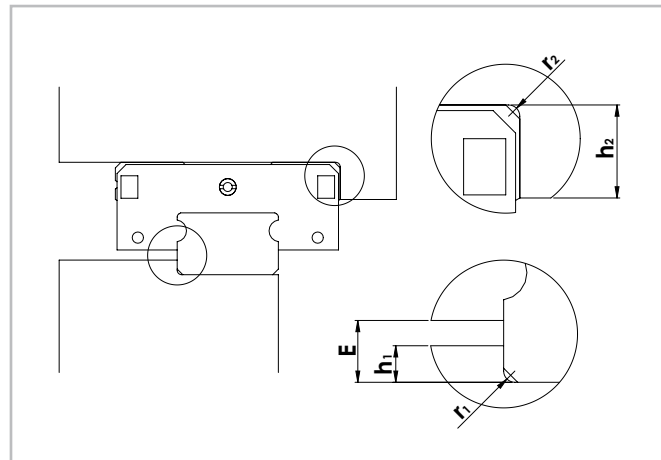

Fig. 19

Dimensions of the stop edges

Type	h_1 [mm]	r_{1max} [mm]	h_2 [mm]	r_{2max} [mm]	E [mm]
MR07M	1.2	0.3	2.8	0.3	1.5
MR09M	1.5	0.3	3	0.3	2.2
MR12M	2.5	0.5	4	0.5	3
MR15M	2.5	0.5	4.5	0.5	4

Tab. 12

Type	h_1 [mm]	r_{1max} [mm]	h_2 [mm]	r_{2max} [mm]	E [mm]
MR09W	2.5	0.3	3	0.3	3.4
MR12W	2.5	0.5	4	0.5	3.9
MR15W	2.5	0.5	4.5	0.5	4

Tab. 13

Geometric and positional accuracy of the mounting surfaces

Inaccuracies of the mounting surface negatively influence the running accuracy and reduce the service life of the Mono Rail Miniature profile rails. If the inaccuracies of the mounting surfaces exceed the values calculated using formulas 14, 15 and 16, the service life is shortened according to formulas 12 und 13.

Mounting surface

The mounting surface should be ground or milled very finely and have a surface roughness of R_a 1.6.

Reference surface

Rail: Both sides of the rails can be used as a reference surface without further marks.

Slider: The reference surface is located across from the running side identified with a notch mark.

Calculation of the positional accuracy

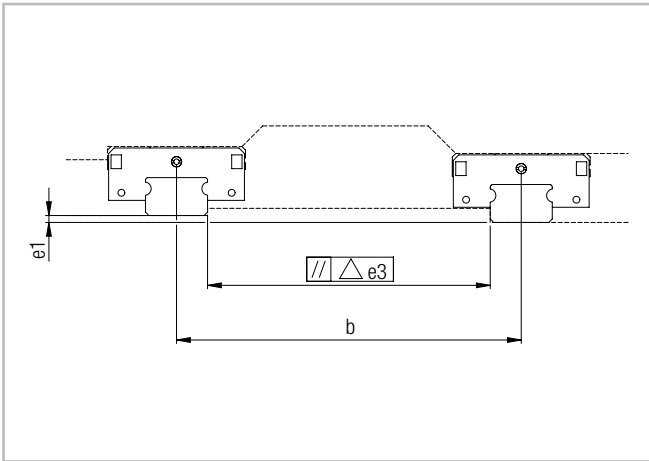

Fig. 20

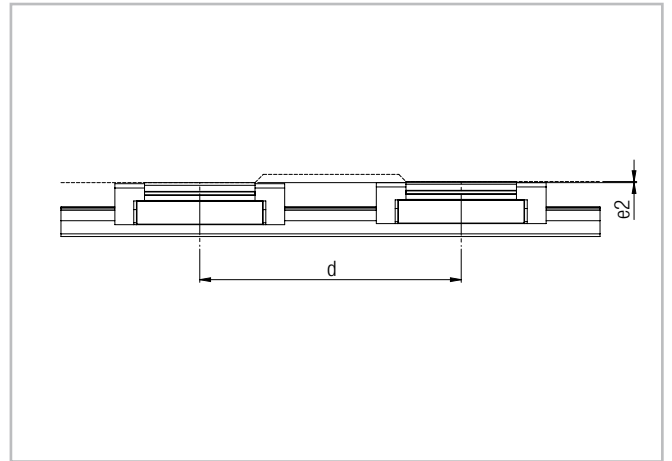

Fig. 21

$$e1 \text{ (mm)} = b \text{ (mm)} \cdot f1 \cdot 10^{-4} \quad \text{Formula 14}$$

$$e2 \text{ (mm)} = d \text{ (mm)} \cdot f2 \cdot 10^{-5} \quad \text{Formula 15}$$

$$e3 \text{ (mm)} = f3 \cdot 10^{-3} \quad \text{Formula 16}$$

Fig. 22

Type	V_0, V_s			V_1		
	f1	f2	f3	f1	f2	f3
MR07MN	5	11	4	3	10	3
MR09MN	5	11	6	4	10	4
MR12MN	6	13	8	4	12	6
MR15MN	7	11	12	5	10	8

Tab. 14

Type	V_0, V_s			V_1		
	f1	f2	f3	f1	f2	f3
MR09WN	2	7	6	2	5	4
MR12WN	3	8	8	2	5	5
MR15WN	2	9	11	1	6	7

Tab. 15

Tightening torque for fixing screws (Nm)

Screw quality 12.9	Steel	Cast iron	Non-ferrous metal
M2	0.6	0.4	0.3
M3	1.8	1.3	1
M4	4	2.5	2

Tab. 16

 Notes

Ordering Key

Rail / slider system

MR	15	M	N	SS	2	V1	P	310	
									Rail length <i>see tab. 17 and 18</i>
									Precision class <i>see pg. 10, tab. 7</i>
									Preload class <i>see pg. 11, tab. 8</i>
									Number of sliders on one rail
									End seal
									Slider type
									Rail type <i>see pg. 8, tab. 3 / pg. 9, tab. 5</i>
									Rail width <i>see pg. 8, tab. 3 / pg.9, tab. 5</i>
									Product type

Ordering example: MR15MN-SS-2-V1-P-310

Hole pattern: 15-7x40-15, see fig. 23, tab. 17 / fig. 24, tab. 18

Hole pattern

Standard width

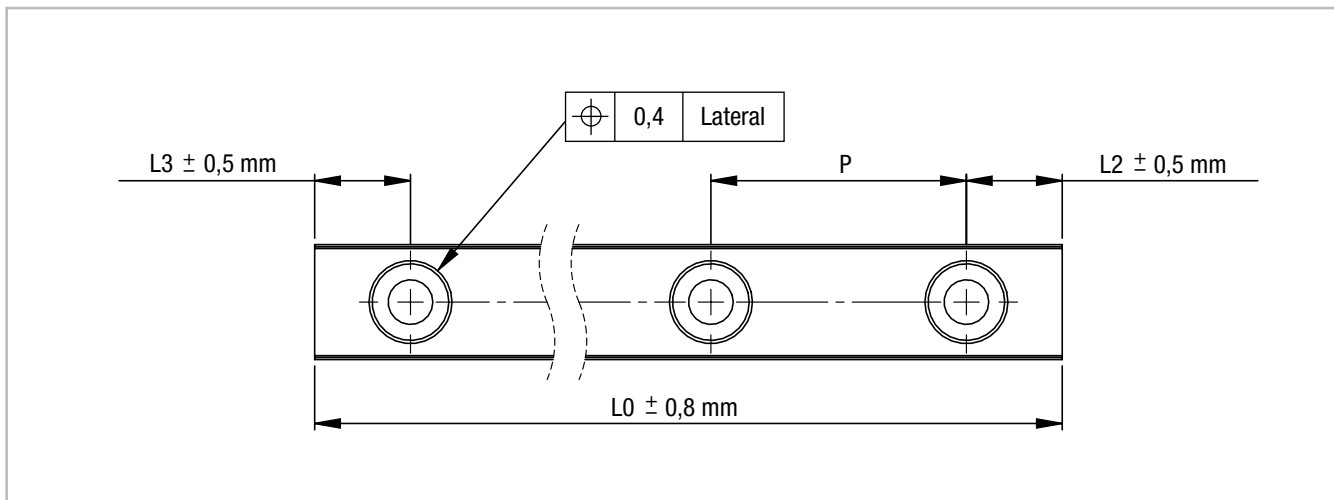

Fig. 23

Size	L_{min} [mm]	Hole pitch P [mm]	L_2, L_{3min} [mm]	L_2, L_{3max} [mm]	L_{max} [mm]
7	40	15	3	10	1000
9	55	20	4	15	
12	70	25	4	20	
15	70	40	4	35	

Tab. 17

Large width

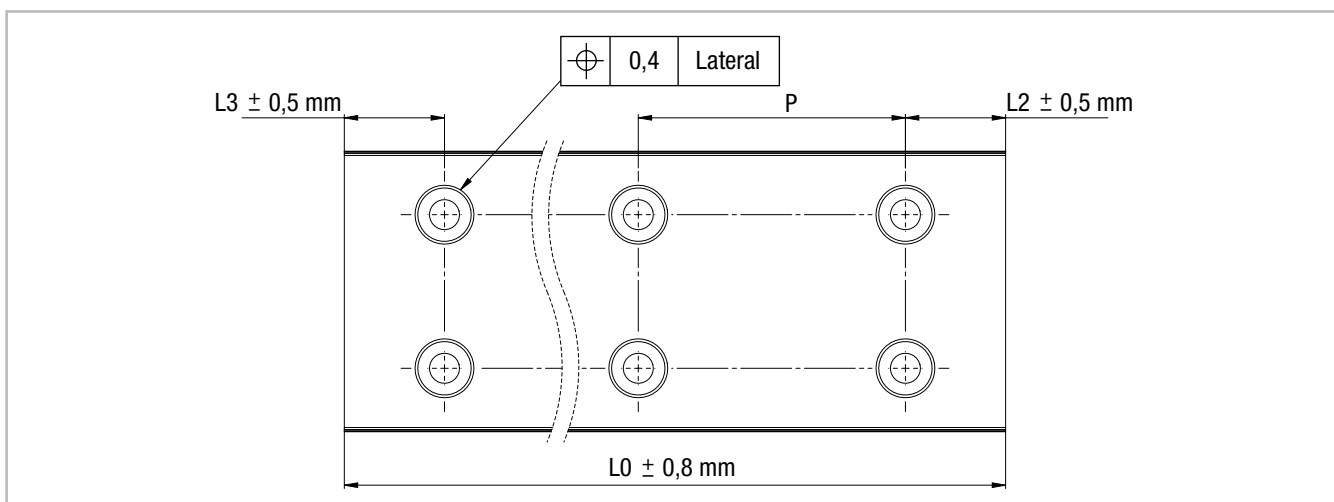

Fig. 24

Size	L_{min} [mm]	Hole pitch P [mm]	L_2, L_{3min} [mm]	L_2, L_{3max} [mm]	L_{max} [mm]
9	50	30	4	25	1000
12	70	40	5	35	
15	110	40		35	

Tab. 18

Portfolio



COMPACT RAIL

Rugged roller sliders with innovative self adjustment



MONO RAIL

Profile guideways for highest degrees of precision



CURVILINE

Curvilinear rails for constant and variable radius



TELESCOPIC RAIL

Smooth-running telescopic linear bearing drawer slides with low deflection under heavy loads

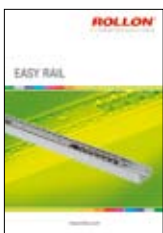

EASY RAIL

Compact, versatile linear bearings



X-RAIL

Roller embossed stainless steel profiles for the use in rough environments



UNILINE

Steel-reinforced, belt-driven linear actuators with hardened steel linear bearings and precision radial ball bearing rollers



LIGHT RAIL

Full and partial extension, lightweight drawer slides

Fold out ordering key

To make this product catalog as simple as possible for you to use, we have included the following easy-to-read chart.

Your advantages:

- Description and ordering designations easy to read at one glance
- Simplified selection of the correct product
- Links to detailed descriptions in the catalog



Italy

ROLLON S.r.l.
Via Trieste 26
I-20059 Vimercate (MB)
Tel.: (+39) 039 62 59 1
Fax: (+39) 039 62 59 205
E-Mail: infocom@rollon.it
www.rollon.it

Germany

ROLLON GmbH
Voisweg 5c
D-40878 Ratingen
Tel.: (+49) 21 02 87 45 0
Fax: (+49) 21 02 87 45 10
E-Mail: info@rollon.de
www.rollon.de

France

ROLLON S.A.R.L.
Les Jardins d'Eole, 2 allée des Séquoias
F-69760 Limonest
Tel.: (+33) (0)4 74 71 93 30
Fax: (+33) (0)4 74 71 95 31
E-Mail: infocom@rollon.fr
www.rollon.fr

Netherlands

ROLLON B.V.
Edisonstraat 32b
NL-6902 PK Zevenaar
Tel.: (+31) 31 65 8 19 99
Fax: (+31) 31 63 4 12 36
E-Mail: info@rollon.nl
www.rollon.nl

USA

ROLLON Corporation
30A Wilson Drive
Sparta, NJ 07871, USA
Tel.: (+1) 973 300 5492
Fax: (+1) 973 300 9030
E-Mail: info@rolloncorp.com
www.rolloncorp.com

Czech Republic

ROLLON s.r.o.
Na Máčovně 1270
CZ-26604 Beroun
Tel.: (+420) 31 16 1 00 50
Fax: (+420) 31 16 1 00 53
E-Mail: info@rollon.cz
www.rollon.cz

All addresses of our global sales partners can also be found in the internet at www.rollon.com